

DESIGN AND DEVELOPMENT OF A LOW LAND CABBAGE HARVESTER PROTOTYPE

Mohd Fazly Mail
Engineering Research Center
Malaysian Agricultural Research and Development Institute (MARDI),
43400 Serdang, Selangor, Malaysia
Email: fazlym@mardi.gov.my

Hafidha Azmon
Engineering Research Center
Malaysian Agricultural Research and Development Institute (MARDI),
43400 Serdang, Selangor, Malaysia
Email: hafidha@mardi.gov.my

Mohd Shahmhaizan Mat Jusoh
Engineering Research Center
Malaysian Agricultural Research and Development Institute (MARDI),
43400 Serdang, Selangor, Malaysia
Email: shahmi@mardi.gov.my

Mohd Nadzim Nordin
Engineering Research Center
Malaysian Agricultural Research and Development Institute (MARDI),
43400 Serdang, Selangor, Malaysia
Email: mnadzim@mardi.gov.my

Rohazrin Abdul Rani
Engineering Research Center
Malaysian Agricultural Research and Development Institute (MARDI),
43400 Serdang, Selangor, Malaysia
Email: rohazrin@mardi.gov.my

Mohd Zubir Idris
Engineering Research Center
Malaysian Agricultural Research and Development Institute (MARDI),
43400 Serdang, Selangor, Malaysia
Email: mzubir@mardi.gov.my

ABSTRACT

This article illustrates the design and development of a mechanical round cabbage harvester. The harvester is suitable for a single row planted of round cabbage. The prototype was designed and developed by MARDI. Harvesting of round cabbage in Malaysia is still done manually. The traditional harvesting method was tedious, causing back pain and exposed the operator to sharp knife when cutting the cabbage head at its base. A study of round cabbage physical properties was conducted to investigate the need of specifications for the design of the harvester. The harvester attached to the side of a modified vehicle that suit to be used on a farm. The developed prototype consists of a frame chassis for carriage the whole set of harvesting mechanism and as a guided to the vehicle driver along a row of cabbage plants, dual-disc cutter with contra rotating disc for cutting the stems and leaves from uprooted cabbage heads, conveyor belt system to transport the cabbage heads directly into the collection basket at the back of the vehicle. The harvesting machine has an adjustable mechanism for cutting purposes. All parts of the harvesting system were powered by an electric motor which tapped from the vehicle. The results showed that the harvester prototype exhibited good ability, feasibility and productivity that met the preliminary mechanized harvesting requirements, which would be a breakthrough for mechanized cabbage harvesting in Malaysia. The developed prototype removes cabbage harvesting by hand, and greatly decreases the amount of hours it takes to harvest a cabbage field.

Key words: round cabbage, harvester prototype, single row planted

INTRODUCTION

Cannonball Cabbage or round cabbage belongs to the Brassicaceae family which is ideally cultivated in temperate and subtropical area (K.V. Peter, 2015). In 2019, round cabbage is planted on 2898 ha where Pahang leads the production with 70,806 Mt from the total of 79,471 yield produced in Malaysia (Jabatan Pertanian Malaysia, 2019).

Due to the lack of highlands to plant vegetables, Malaysia often imports cabbage from China and Indonesia to supply the local market. Malaysia, on the other hand, is starting to use lowland crop technologies for cabbage, which may minimise reliance on imports. The lowland cabbage is important in order to support the production of the local highland cabbage grower (I. Z. Ibrahim

et al., 2019). The temperate environment is not an issue to cultivate the round cabbages on low land regions, since the suitable variety of seeds have been introduced to fit the growing conditions in slightly higher temperature than the high land. Malaysia can provide 80K MT of cabbage per year with only highland crops; but, with the latest technologies to grow cabbage in the lowlands, the overall supply is projected to increase by 40%.

The scarcity of workers is a big issue in cabbage cultivation, and it has grown worse for high scale crop production. Apart from land, the crucial agricultural resources in planting cabbage are faced when labour is not enough to harvest the yields. Every grower has a problem with harvesting cabbage since it is the most tedious and cost intensive activity in cabbage production (Rezahosseini, 2019). The harvesting activity required almost 40% of the total workload in cabbage production (Wang, J. et al., 2014). An alternative of mechanization is required to solve the problem. The large area of cultivation justified the high overhead cost if mechanization is applied (Glancey and Kee, 2005). Therefore, the implementation of the machine in vegetable production is the best bet. Apart from reducing dependency on conventional inputs and labour, mechanization practice brings the grower towards increased production and improved income and standard of living when vegetables are produced in a large scale.

However, the development of the cabbage harvester requires to comply with a few aspects before it can be adopted in the field. It involves the economic, complexity of the harvesting method and technical issue on the precision related to horticultural aspects. Cutting heads of the cabbage need a clean crop detachment from the roots without damaging the flesh of the crop to maximize the storage life. There are many researchers studying the harvesting of vegetables via mechanization. One of the technology related was a single-row Egyptian cabbage harvester with the serrated edge cutter discs developed in Egypt (M. Ibrahim & Didamony, 2020). In Russia, cabbage harvester using collecting stack of head in case on trailers has been invented (Alatyrev et al., 2020). All technologies developed were using several methods in cutting and harvesting yields.

This paper focuses on developing a low land cabbage harvester prototype. In consideration of the prototype development, the analysis of cabbage mechanical properties and the planting characteristic of cabbage is considered. The round cabbages are planted in a row on each bed, and the harvester developed is focused on cutting heads of each cabbage and collecting the yields out of the field. The study has been done to evaluate the performance of the cabbage harvester to leverage the potential of mechanization to support and improve the efficiency of low land cabbage production in Malaysia.

MATERIALS AND METHODS

Machine development

The following design requirements were used as a guide to develop the cabbage harvester prototype. The prototype should have the following construction features; simple in design and construction, cutting mechanism able to cut the cabbage without major damage/loss, easy control during turning and movement off road, constructed from durable materials, and one-person operated machine.

The physical properties of cabbage (F1 311 All Season) were measured to obtain design requirement data for the development of the harvesting mechanism (Figure 1). Table 1 summarizes the data on the properties analyzed. The stem cutting force for cabbage was obtained to identify the minimum force required to cut the cabbage stem.

Figure 1: Physical properties of cabbage (F1 311 All Season); (A) canopy width, (B) head size, (C) plant height, (D) stem height above ground, (E) stem diameter

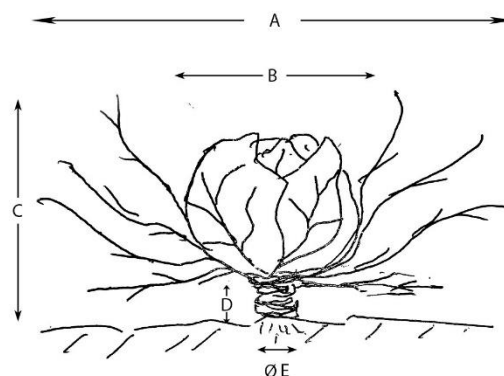

Table 1: Physical and mechanical properties of cabbage (F1 311 All Season)

Cabbage Characteristic	Average Value
Canopy width, mm	603.9
Head size, mm	199.4
Head weight, kg	1.64
Plant height, mm	260
Stem height above ground, mm	93
Stem diameter, mm	23.9
Cut force of cutting stem, N	87.3

The design concept and considerations outlined below (Figure 2) were developed for the prototype. There were three main ideas applied in this design. Firstly, the transporter was selected and modified to suit off road condition. It was also modified to carry loads at the rear part. Secondly, the cutting mechanism should be just below the cabbage in order to cut the cabbage successfully. The cutting mechanism was operated by electric motors which powered two blades to rotate in opposite directions. The third concept applied in this design was the conveyor system construction. The conveyor system was designed with several partitions considering the cabbage size and weight to ensure no cabbage was falling off to the ground. The conveyor system also was built to transport the cabbage towards the rear part of the harvester prototype.

The layout and schematic drawing for a cabbage harvester was shown in Figure 2. The constructed prototype of a cabbage harvester prototype was shown in Figure 3. The prototype consists of a mainframe to be attached the cutting mechanism and the conveyor system. The mainframe was made of mild steel material with combination of angle bars (1 inch x 1 inch- 2mm thickness, 2 inches x 2 inches- 2mm thickness) ,hollow square (2 inches x 1 inches – 2mm thickness) and C-channel (3 inches x 2 inches - 3mm thickness) while the circular cutting blades were 14 inches diameter, 60 tooth and 350mm thickness operating at speed of 1800rpm. The circular cutting blades were made from carbide steel to ensure long lasting for cutting purposes. The conveyor system frame was made from aluminium because of its light weight. The partition on the conveyor system was designed at 5mm height to hold the cabbage during movement and transportation.

Figure 2: Design concept of cutting mechanism for cabbage harvester prototype

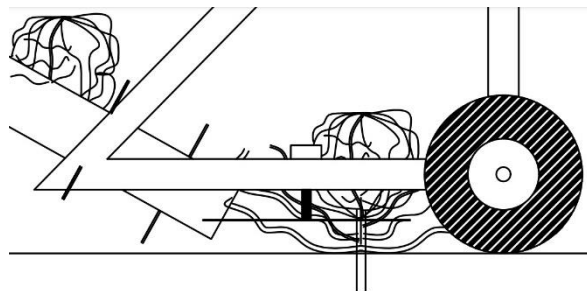
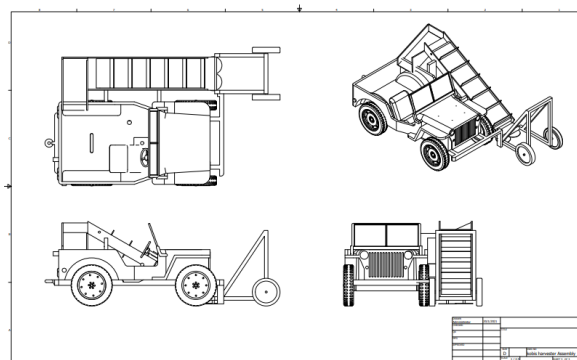

Figure 3: Schematic drawing for a cabbage harvester prototype



Computer simulation

The development of the cabbage harvester started with the design phase, which provides a general overview of the design part and construction. The design analysis was carried out using computer simulation to forecast stresses and tensile strength with particular forces and constraints. There were three factors concerned with simulating the pushing force; rolling resistance, and body weight, while Von Mises stress, first principal stress, and third principal stress were the effects measured on the prototype. The result from the simulation described on the displacement and safety factor.

Autodesk inventor's integrated stress analysis tool software was used to run the simulation. Solid 3D drawing of the machine components, parts and assembly were constructed in Autodesk Inventor 2016 3D modeling environment and then transferred to Stress Analysis environment. It was used to estimate stresses that occurred on the frame when forces exerted during operation. All components material is assigned as welded steel with a yield strength of 207 MPa and young modulus of 220 GPa. The analysis was done by taking a worst scenario operation condition, when the cutting blade failed to cut the cabbage and create the pendicular forces directly to the cutting blades at 87 newton forces. The most affected structure for the condition is the guide frame. To minimize the analysis time taken, only the guide frame was analysed. The guide frame is constrained at three places, at the brackets, that mounts the frame to the vehicle. The wheel rolling resistance was assumed too small and neglected in the analysis.

Machine operation

The harvester travels along the harvested section of the field as mention in Figure 4, directing the cutting apparatus in along the row to harvest the crop. The cabbage plants are aligned in the longitudinal and transverse planes, as well as in height, while the cutting system is operating. The height of the cutter can be move up and down to align with the crop. This is to ensure that the cutting blade will not damage the cabbage. The cabbage then will be cut off when the machine passed through the planting bed. The cut cabbage will fall on a conveyor belt and then will be moved to the collector behind the harvester.

Figure 4: The harvester position during the harvesting process

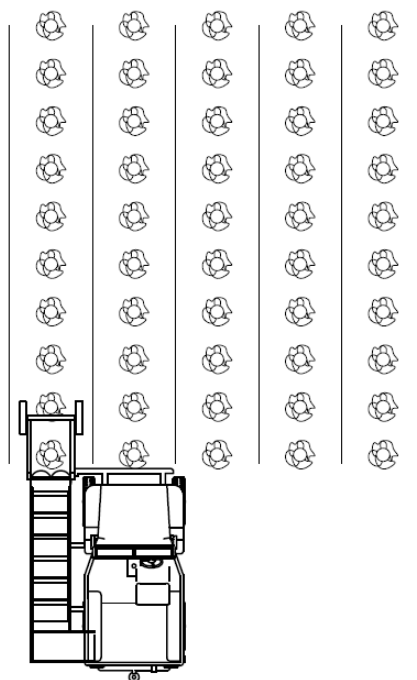

Machine operational functional performance

The machine mechanical functioning of the cabbage harvester components was observed without taking any work rate data. Observations were made on implement's ease of operation, harvesting ground level and height adjustment control. The frame chassis for carriage the whole set of harvesting mechanism, a guided to the vehicle driver along a row of cabbage plants, dual-disc cutter with contra rotating disc for cutting the stems and leaves from uprooted cabbage heads, conveyor belt system to transport the cabbage heads directly into the collection basket at the back of the vehicle were also observed. The operational practical efficiency observations were made on the forward speeds appropriate for the tin-tailing soil and were repeated several times to obtain the optimal speed without harming the cabbage head and for the operator's ease of handling the equipment. The completeness period was observed, which included cutting, conveying, and filling the cabbage into the basket.

RESULTS AND DISCUSSION

Machine performance

Figure 5: Constructed prototype of a cabbage harvester prototype; (a) front view (b) rear view



(a)



(b)

Computer simulation result

The analysis result shows the highest stress of 54.44 MPa occurred at the mounting bracket near to the cutting blade as shown in Figure 6. This stress gives the lowest safety factor of 5.0673, which means the material used for the frame structure construction is 5 times stronger to hold the forces occurred when the worst scenario happened. There is a little displacement was detected to the frame structure and not much affect the dimension.

Figure 6: Value of 1st Principal Stress on the design analysis of a cabbage cutting mechanism



Table 2: Result summary on the design analysis of a cabbage cutting mechanism

Name	Minimum	Maximum
Volume	3535150 mm ³	
Mass	27.7509 kg	
Von Mises Stress	0.000723382 MPa	40.85 MPa
1st Principal Stress	-15.8817 MPa	54.4404 MPa
3rd Principal Stress	-53.9869 MPa	19.7828 MPa
Displacement	0 mm	0.783304 mm
Safety Factor	5.06731 ul	15 ul

Machine operational functional performance observations

The harvester attached to the side of a modified vehicle that suit to be used in a farm. The developed prototype consists of a frame chassis for carriage the whole set of harvesting mechanism and as a guided to the vehicle driver along a row of cabbage plants, dual-disc cutter with contra rotating disc for cutting the stems and leaves from uprooted cabbage heads, conveyor belt system to transport the cabbage heads directly into the collection basket at the back of the vehicle. The harvesting machine has an adjustable mechanism for cutting purposes. All parts of the harvesting system were powered by an electric motor.

From the field tests observations, it was apparent that the workers applied less physical efforts when harvesting the cabbage by using the developed harvester compared to the manual. The prototype was functionally tested with cabbage on the tin-tailing soil at the MARDI Research Station in Kundang, Selangor. The crops were planted on raised beds. The mechanical components of the cabbage harvester prototype worked well at operating speeds to harvest the cabbage.

The prime mover was modified to suit off road condition and to carry the harvested cabbage at the rear part of the machine. The dual disc cutter used for cutting mechanism succeed to cut the cabbage stem. The cutting mechanism was operated by two 12v electric motors, 30 watt power and operating at 1800rpm, which powered two blades to rotate in opposite directions. The conveyor system that used to convey the harvested cabbage into the collection basket was greatly functioned. There were no cabbage fell off to the ground as the conveyor system equipped with several partition stings.

The results showed that the harvester prototype exhibited good ability, feasibility and productivity that met the preliminary mechanized harvesting requirements, which would be a breakthrough for mechanized cabbage harvesting in Malaysia. The developed prototype removes cabbage harvesting by hand, and greatly decreases the amount of hours it takes to harvest a cabbage field. For future research, a further study on the cabbage harvester field performances will be conducted.

CONCLUSION

The low land cabbage harvester on row crops has been designed, developed, and evaluated. The prototype implement satisfies almost all of its design requirements and objectives, especially in terms of general performance and effectiveness in executing the design tasks. The results showed that the harvester prototype exhibited good ability, feasibility and productivity that met the preliminary mechanized harvesting requirements, which would be a breakthrough for mechanized cabbage harvesting in Malaysia. The developed prototype removes cabbage harvesting by hand, and greatly decreases the amount of hours it takes to harvest a cabbage field. Harvester turning and travel at the headland take up much of the 'unproductive' time. In reality, this could be minimized by better managing field work strategies to increase field productivity. Further study will be carried out to determine field performance efficiencies of the low land cabbage harvester prototype.

ACKNOWLEDGEMENTS

The authors thank MARDI Kundang Research Station and their staffs for providing the low land cabbage plots for the tests and their assistance during the field tests. We wished to specially thank our team members Mr. Noraznal Mohd Zainal, Miss Norahshekin Abdul Rahman, Mr. Zawayi Mat, Miss Siti Ashah Abdul Rahim, Zul Fadzli Marzuki, Mohd Khairil Izani Ishak, Ahmad Kamil Zolkafli, Mustafar Yaakob, Muhammad Akmal Mohd Salleh, Zulhazmi Abu Bakar, Joehari Abdul Rani, Mohammad Shamsul Idris, Mohd Rosli Pairan, Zainal Abidin Abu Bakar for their dedication and valuable contributions rendered during the tests conducted on the cabbage harvester prototype.

REFERENCES

- Alatyrev, S. S., Kruchinkina, I. S., Alatyrev, A. S., Vasilyev, A. O., & Andreev, R. V. (2020). Technology and parameters of cabbage machine harvesting by careful stacking of heads in containers. *IOP Conference Series: Earth and Environmental Science*, 433(1). <https://doi.org/10.1088/1755-1315/433/1/012005>
- Glancey, J. L., & Kee, W. E. (2005). Engineering aspects of production and harvest mechanization for fresh and processed vegetables. *HortTechnology*, 15(1), 76–79. <https://doi.org/10.21273/horttech.15.1.0076>
- Ibrahim, I. Z., Manickam, T., Iskandar, N. L., Noor, S., Abdul, A., Mutalib, F. A., Ghazali, S., Abdul, N., & Zainol, R. (2019).

Teknologi penanaman kubis bulat di tanah rendah secara organik (Lowland organic cabbage production technology). 17, 55–65.

Ibrahim, M., & Didamony, E. (2020). *Fabrication and Evaluation of a Cabbage Harvester Prototype*. 1–11.

Jabatan Pertanian Malaysia. (2019). *Vegetables and Cash Crops Statistic 2019*.
http://www.doa.gov.my/index/resources/aktiviti_sumber/sumber_awam/maklumat_pertanian/perangkaan_tanaman/booklet_statistik_tanaman_2020.pdf

K.V. Peter, P. H. (2015). *Handbook of Vegetables* (Issue vol 3). Studium Press.

Rezahosseini, A. (2019). Development and Field Evaluation of a Cabbage Harvester Unit. *Journal of Agricultural Machinery*, 9(1). <https://doi.org/10.22067/JAM.V9I1.62703>

Wang, • J. (2014). Vegetable mechanized harvesting technology and its development. *Transactions of Chinese Society of Agricultural Machinery*, 45(2), 81–87. <https://doi.org/10.6041/j.issn.1000-1298.2014.02.014>